

1.5MHz Synchronous Step-down DC-DC Converter
AP3417C

General Description

The AP3417C is a high efficiency step-down DC-DC voltage converter. The chip operation is optimized by peak-current mode architecture with built-in synchronous power MOSFET switchers. The oscillator and timing capacitors are all built-in providing an internal switching frequency of 1.5MHz that allows the use of small surface mount inductors and capacitors for portable product implementations.

Integrated Soft Start (SS), Under Voltage Lock Out (UVLO), Thermal Shutdown Detection (TSD) and Short Circuit Protection are designed to provide reliable product applications.

The device is available in adjustable output voltage version ranging from 0.6V to $0.9 \times V_{IN}$ when input voltage range is from 2.5V to 5.5V, and is able to deliver up to 1A. It is also available in fixed voltage versions of 1.2V, 1.8V and 3.3V without external feedback resistance.

The AP3417C is available in SOT-23-5 and DFN-2x2-6 packages.

Features

- High Efficiency Buck Power Converter
- Wide Input Voltage Range: 2.5V to 5.5V
- Adjustable Output Voltage: 0.6V to $0.9 \times V_{IN}$
- Low $R_{DS(ON)}$ Internal Switches: $200m\Omega$ ($V_{IN}=5V$)
- Built-in Power Switches for Synchronous Rectification with High Efficiency
- Output Current: 1.0A
- Feedback Voltage: 600mV
- 1.5MHz Constant Frequency Operation
- Thermal Shutdown Protection
- Low Dropout Operation at 100% Duty Cycle
- No Schottky Diode Required
- Input Over Voltage Protection
- Output Over Voltage Protection
- Over Current Protection

Applications

- Post DC-DC Voltage Regulation
- PDA and Notebook Computer

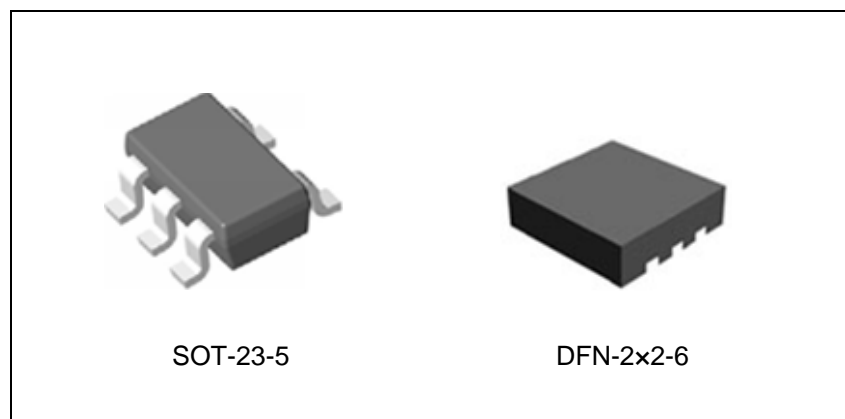

Figure 1. Package Types of AP3417C

1.5MHz Synchronous Step-down DC-DC Converter
AP3417C
Pin Configuration

Figure 2. Pin Configuration of AP3417C (Top View)

Pin Description

Pin Number		Pin Name	Function
SOT-23-5	DFN-2x2-6		
1	2	EN	Chip enable pin. Active high
2	5	GND	Ground pin
3	4	LX	Switch output pin
4	3	VIN	Power supply
5	6	FB	Feedback voltage of output
	1	NC	No internal connection

Functional Block Diagram

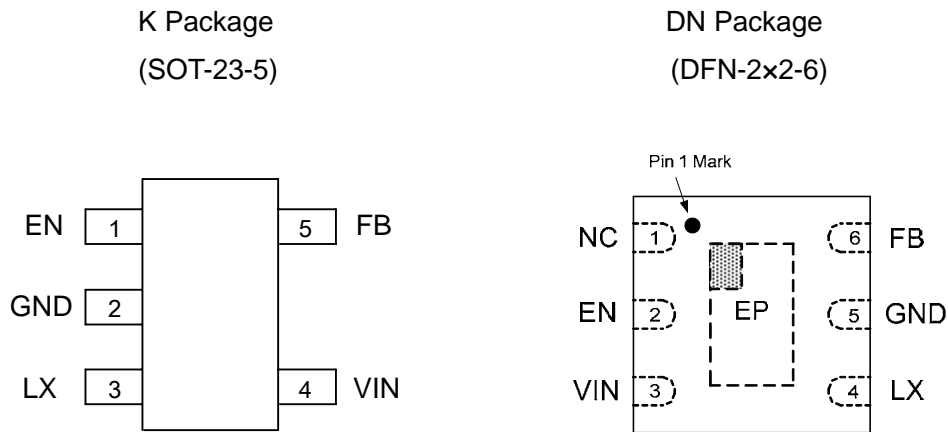
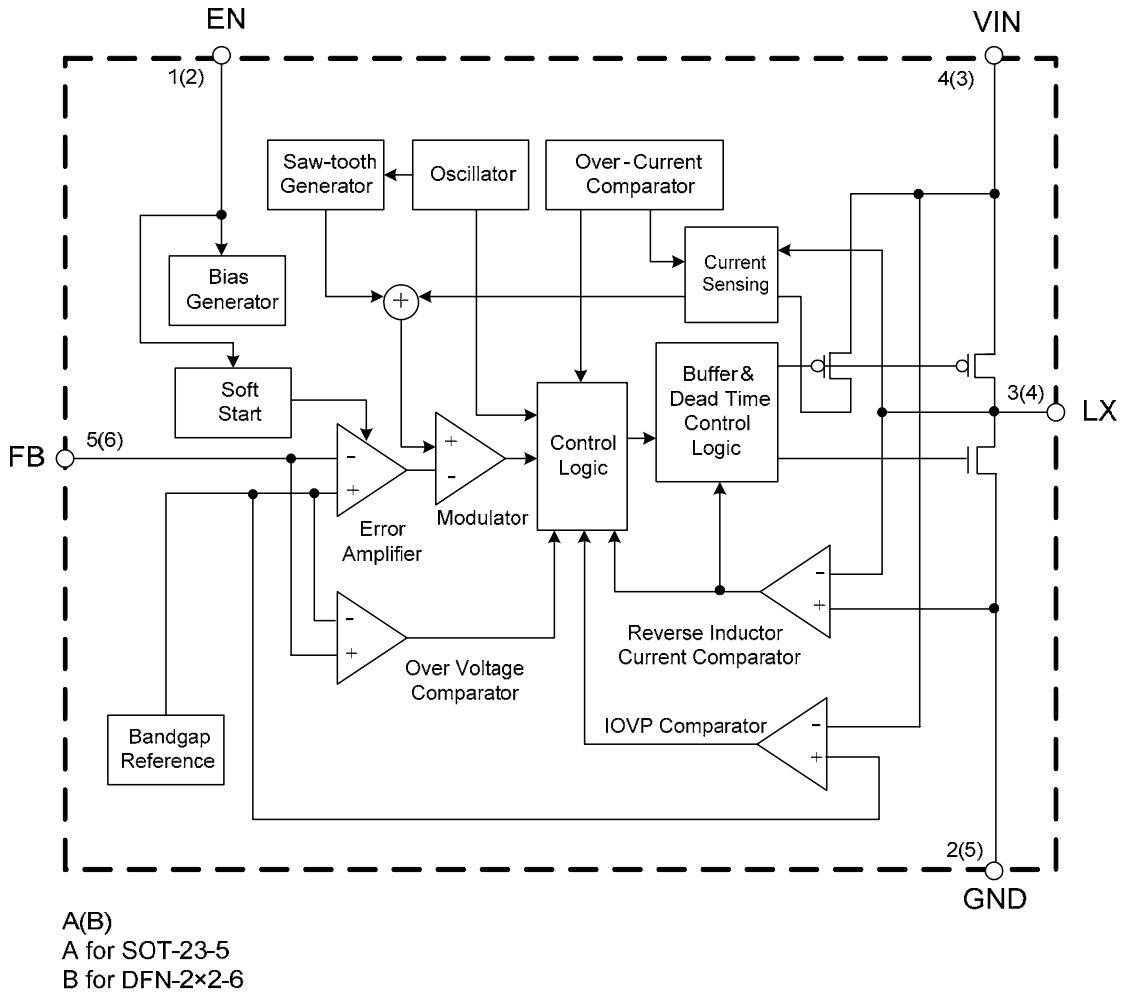

Figure 3. Functional Block Diagram of AP3417C



1.5MHz Synchronous Step-down DC-DC Converter

AP3417C

Ordering Information

For ADJ Version

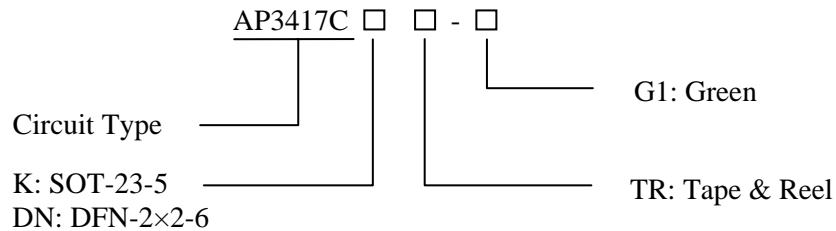

For Fixed Versions

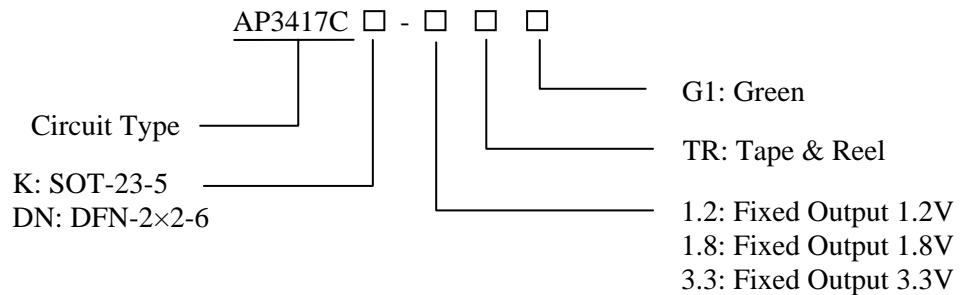

Package	Temperature Range	Part Number	Marking ID	Packing Type
SOT-23-5	-40 to 85°C	AP3417CKTR-G1	G4I	Tape & Reel
		AP3417CK-1.2TRG1	G4U	Tape & Reel
		AP3417CK-1.8TRG1	G4V	Tape & Reel
		AP3417CK-3.3TRG1	G4W	Tape & Reel
DFN-2×2-6	-40 to 85°C	AP3417CDNTR-G1	BH	Tape & Reel
		AP3417CDN-1.2TRG1	BL	Tape & Reel
		AP3417CDN-1.8TRG1	BM	Tape & Reel
		AP3417CDN-3.3TRG1	BN	Tape & Reel

BCD Semiconductor's Pb-free products, as designated with "G1" suffix in the part number, are RoHS compliant and green.

**1.5MHz Synchronous Step-down DC-DC Converter****AP3417C****Absolute Maximum Ratings (Note 1)**

Parameter	Symbol	Value		Unit
Input Voltage for the MOSFET Switch	V_{IN}	0 to 6.0		V
Enable Input Voltage	V_{EN}	-0.3 to $V_{IN}+0.3$		V
LX Pin Switch Current	I_{LX}	1.8		A
Power Dissipation (on PCB, $T_A=25^\circ\text{C}$)	P_D	SOT-23-5	0.4	W
		DFN-2x2-6	1.89	
Thermal Resistance (Junction to Ambient, Simulation)	θ_{JA}	SOT-23-5	250	$^\circ\text{C/W}$
		DFN-2x2-6	53	
Thermal Resistance (Junction to Case, Simulation)	θ_{JC}	SOT-23-5	130	$^\circ\text{C/W}$
Operating Junction Temperature	T_J	155		$^\circ\text{C}$
Storage Temperature	T_{STG}	-55 to 150		$^\circ\text{C}$
Operating Temperature	T_{OP}	-40 to 85		$^\circ\text{C}$
ESD (Machine Model)	V_{MM}	200		V
ESD (Human Body Model)	V_{HBM}	2000		V

Note 1: Stresses greater than those listed under “Absolute Maximum Ratings” may cause permanent damage to the device. These are stress ratings only, and functional operation of the device at these or any other conditions beyond those indicated under “Recommended Operating Conditions” is not implied. Exposure to “Absolute Maximum Ratings” for extended periods may affect device reliability.

Recommended Operating Conditions

Parameter	Symbol	Min	Max	Unit
Supply Input Voltage	V_{IN}	2.5	5.5	V
Operating Ambient Temperature	T_A	-40	85	$^\circ\text{C}$
Operating Junction Temperature	T_J	-40	125	$^\circ\text{C}$



1.5MHz Synchronous Step-down DC-DC Converter

AP3417C

Electrical Characteristics

$V_{IN}=V_{EN}=5V$, $V_{OUT}=1.2V$, $V_{FB}=0.6V$, $L=2.2\mu H$, $C_{IN}=4.7\mu F$, $C_{OUT}=10\mu F$, $T_A=25^\circ C$, unless otherwise specified.

Parameters	Symbol	Conditions	Min	Typ	Max	Unit
Input Voltage Range	V_{IN}		2.5		5.5	V
Shutdown Current	I_{OFF}	$V_{EN}=0$			0.1	μA
Active Current	I_{ON}	$V_{FB}=0.55V$		220		μA
Regulated Feedback Voltage	V_{FB}	For Adjustable Output Voltage	0.588	0.6	0.612	V
Output Voltage	V_{OUT}	Fixed Output 1.2V	1.176	1.2	1.224	V
		Fixed Output 1.8V	1.764	1.8	1.836	
		Fixed Output 3.3V	3.234	3.3	3.366	
Regulated Output Voltage Accuracy	$\Delta V_{OUT}/V_{OUT}$	$V_{IN}=2.5V$ to $5.5V$, $I_{OUT}=0$ to $1.0A$	-3		3	%
Peak Inductor Current	I_{PK}		1.5	1.9		A
Oscillator Frequency	f_{OSC}	$V_{IN}=2.5V$ to $5.5V$	1.2	1.5	1.8	MHz
PMOSFET $R_{DS(ON)}$	$R_{DS(ON)P}$	$V_{IN}=5V$		200		$m\Omega$
NMOSFET $R_{DS(ON)}$	$R_{DS(ON)N}$	$V_{IN}=5V$		200		$m\Omega$
EN High Level Input Voltage	V_{EN_H}		1.5			V
EN Low Level Input Voltage	V_{EN_L}				0.4	V
EN Input Current	I_{EN}				0.1	μA
Soft Start Time	t_{SS}			400		μs
Maximum Duty Cycle	D_{MAX}		100			%
Under Voltage Lock Out Threshold	V_{UVLO}	Rising		2.3		V
		Falling		2.1		
		Hysteresis		0.2		
Thermal Shutdown	T_{SD}	Hysteresis= $30^\circ C$		155	160	$^\circ C$



1.5MHz Synchronous Step-down DC-DC Converter

AP3417C

Typical Performance Characteristics

$V_{IN}=5V$, $T_A=25^{\circ}C$, unless otherwise noted.

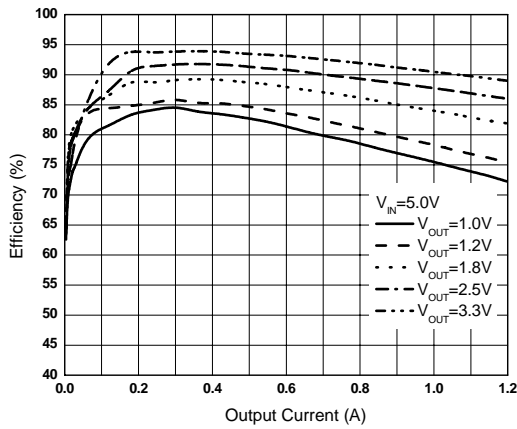

Figure 4. Efficiency vs. Output Current

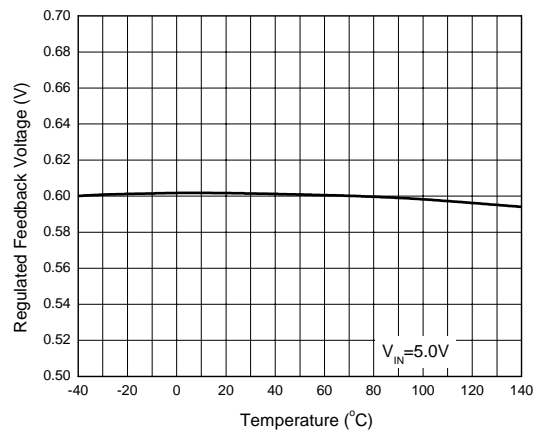

Figure 5. Regulated Feedback Voltage vs. Temperature

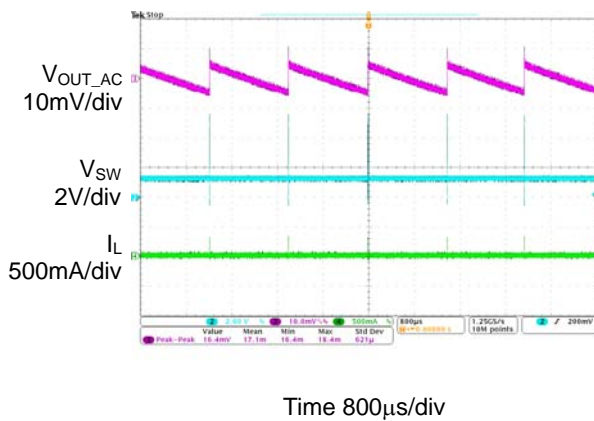

Figure 6. Output Ripple ($I_{OUT}=0A$)

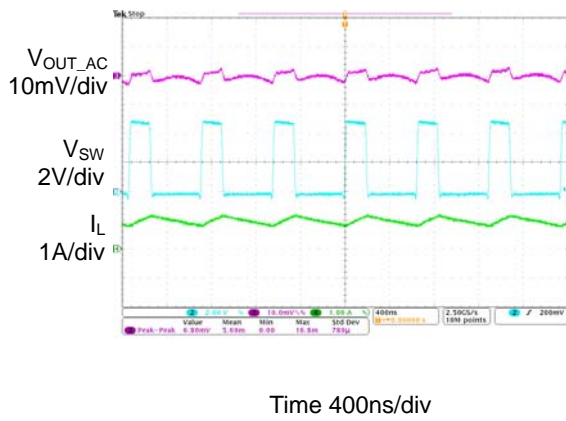
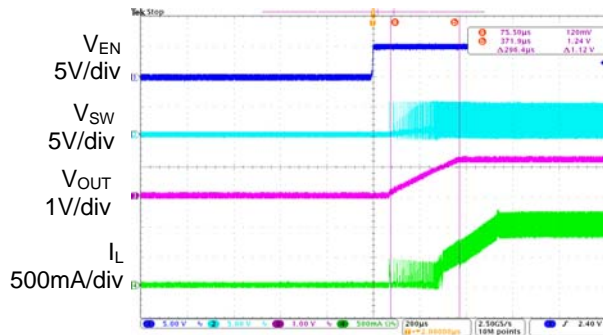
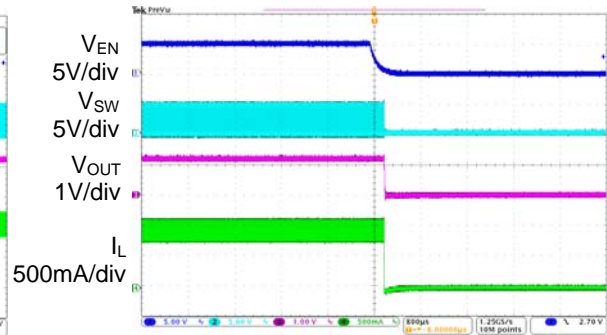

Figure 7. Output Ripple ($I_{OUT}=1A$)

1.5MHz Synchronous Step-down DC-DC Converter
AP3417C
Typical Performance Characteristics (Continued)
 $V_{IN}=5V$, $T_A=25^{\circ}C$, unless otherwise noted.

Time 200µs/div

 Figure 8. Enable Turn On ($I_{OUT}=1A$)

Time 800µs /div

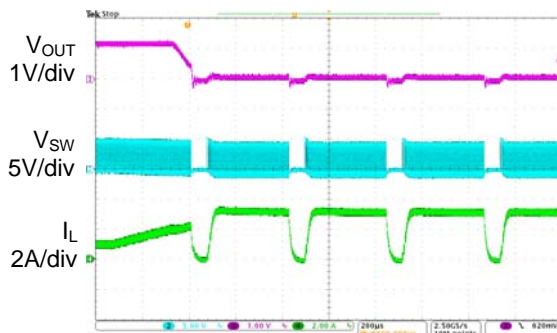
 Figure 9. Enable Turn Off ($I_{OUT}=1A$)

Time 200µs/div

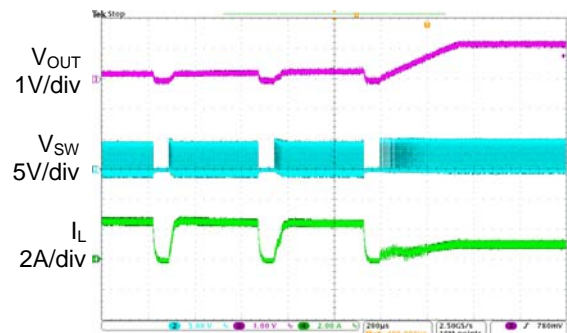
 Figure 10. Short Circuit Protection ($I_{OUT}=1A$)

Time 200µs /div

 Figure 11. Short Circuit Protection Recovery ($I_{OUT}=1A$)

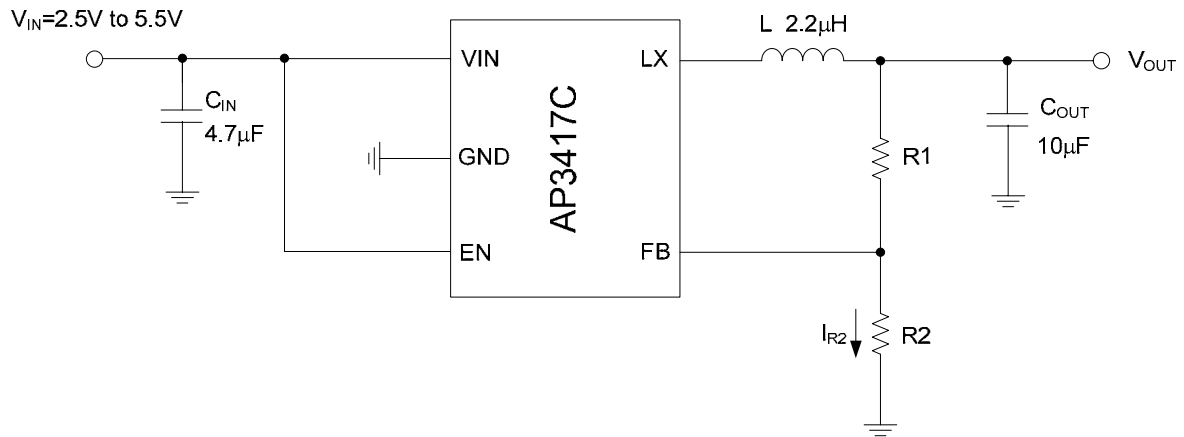
1.5MHz Synchronous Step-down DC-DC Converter
AP3417C
Typical Application

For ADJ Version

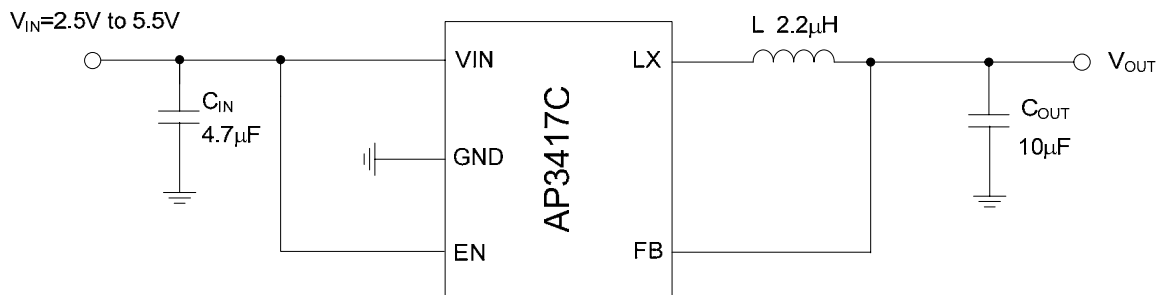

For Fixed Versions

Figure 12. Typical Applications of AP3417C

Table 1. Component Guide

V _{OUT} (V)	R1 (kΩ)	R2 (kΩ)	L (µH)
3.3	450	100	2.2
2.5	320	100	2.2
1.8	200	100	2.2
1.2	100	100	2.2
1.0	66	100	2.2

1.5MHz Synchronous Step-down DC-DC Converter

AP3417C

Mechanical Dimensions

SOT-23-5

Unit: mm(inch)

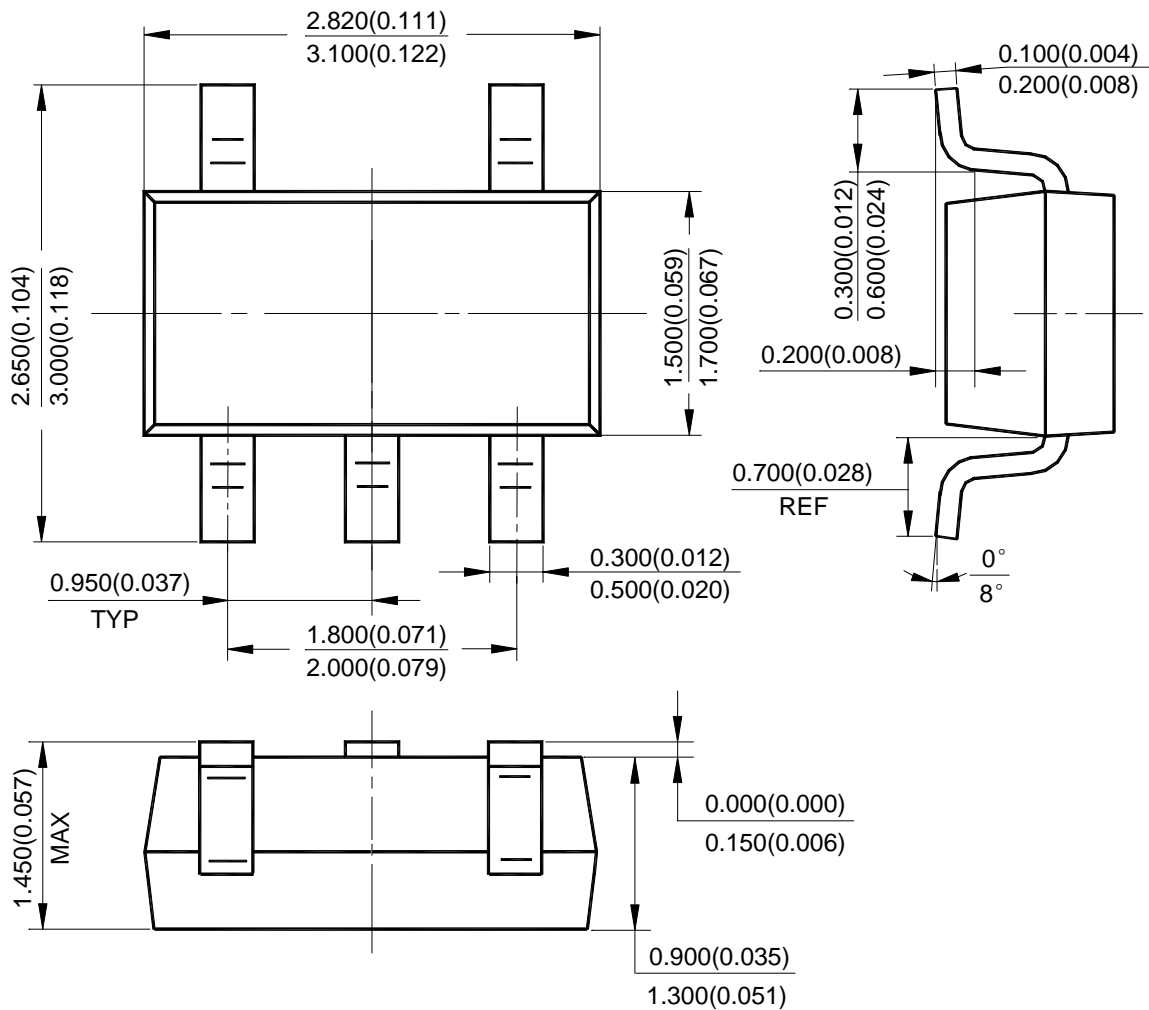

1.5MHz Synchronous Step-down DC-DC Converter

AP3417C

Mechanical Dimensions (Continued)

DFN-2x2-6

Unit: mm(inch)

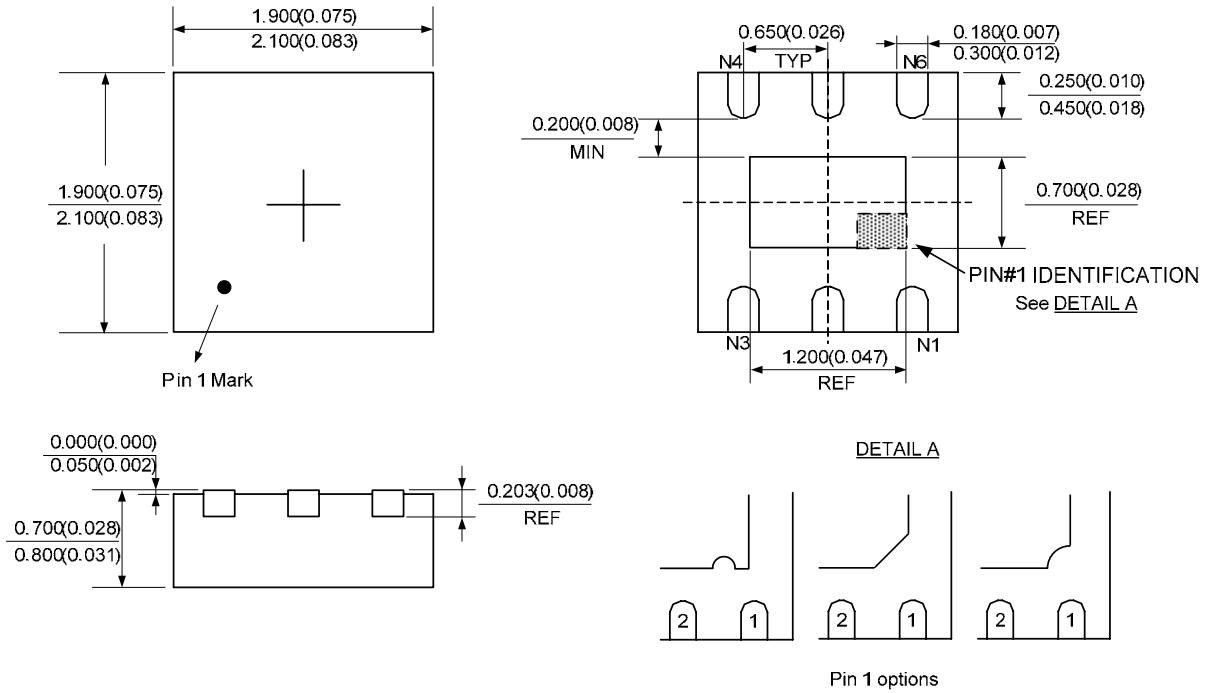



BCD Semiconductor Manufacturing Limited

<http://www.bcdsemi.com>

IMPORTANT NOTICE

BCD Semiconductor Manufacturing Limited reserves the right to make changes without further notice to any products or specifications herein. BCD Semiconductor Manufacturing Limited does not assume any responsibility for use of any its products for any particular purpose, nor does BCD Semiconductor Manufacturing Limited assume any liability arising out of the application or use of any its products or circuits. BCD Semiconductor Manufacturing Limited does not convey any license under its patent rights or other rights nor the rights of others.

MAIN SITE

- Headquarters

BCD (Shanghai) Micro-electronics Limited

No. 1600, Zi Xing Road, Shanghai Zizhu Science-based Industrial Park, 200241, P. R. C.
Tel: +86-021-2416-2266, Fax: +86-021-2416-2277

- Wafer Fab

Shanghai SIM-BCD Semiconductor Manufacturing Co., Ltd.

800 Yishan Road, Shanghai 200233, China
Tel: +021-6485-1491, Fax: +86-021-5450-0008

REGIONAL SALES OFFICE

Shenzhen Office

Shanghai SIM-BCD Semiconductor Manufacturing Co., Ltd., Shenzhen Office

Unit A Room 1203, Skyworth Bldg., Gaoxin Ave.1.S., Nanshan District
Shenzhen 518057, China

Tel: +86-0755-8660-4900, Fax: +86-0755-8660-4958

Taiwan Office (Taipei)

BCD Semiconductor (Taiwan) Company Limited

3F, No.17, Lane 171, Sec. 2, Jiu-Zong Rd., Nei-Hu Dist., Taipei(114), Taiwan, R.O.C
Tel: +886-2-2656-2808

Fax: +886-2-2656-2806/26562950

Taiwan Office (Hsinchu)

BCD Semiconductor (Taiwan) Company Limited

8F, No.176, Sec. 2, Gong-Dao 5th Road, East District
HsinChu City 300, Taiwan, R.O.C

Tel: +886-3-5160181, Fax: +886-3-5160181

USA Office

BCD Semiconductor Corp.

48460 Kato Road, Fremont, CA 94538, USA
Tel: +1-510-668-1950

Fax: +1-510-668-1990

Korea Office

BCD Semiconductor Limited Korea office.

Room 101-1112, Digital-Empire II, 486 Sin-dong,
Yeongtong-Gu, Suwon-city, Gyeonggi-do, Korea

Tel: +82-31-695-8430