

LOW NOISE PRE AMPLIFIER FOR AUTOREVERSE CAR STEREO.

KIA2025P/F contains dual amplifier, forward, reverse control switches and metal, normal tape equalizer control switches.

FEATURES

- High Voltage Gain
: $G_{VO}=100\text{dB(Typ.)}$ ($V_{CC}=9\text{V}$, $f=1\text{kHz}$)
- No input coupling capacitor
- Low Noise (equivalent noise voltage)
: $V_{NI}=0.6\mu\text{Vrms(Typ.)}$ ($V_{CC}=9\text{V}$, $R_g=620\Omega$,
 $BW=20\text{Hz}\sim 20\text{kHz}$, NAB EQ)
- Low Distortion : $\text{THD}=0.01\%$ (Typ.)
- Operating supply voltage range : $V_{CC(\text{opr})}=6\sim 16\text{V}$

MAXIMUM RATINGS ($T_a=25^\circ\text{C}$)

CHARACTERISTIC	SYMBOL	RATING	UNIT
Supply Voltage	V_{CC}	16	V
Power Dissipation (Note)	P_D	350	mW
Operating Temperature	T_{opr}	$-30\sim 85$	$^\circ\text{C}$
Storage Temperature	T_{stg}	$-55\sim 150$	$^\circ\text{C}$

(Note) Derated above $T_a=25^\circ\text{C}$ in the proportion of $6\text{mW}/^\circ\text{C}$ for KIA2025P and of $2.8\text{mW}/^\circ\text{C}$ for KIA2025F.

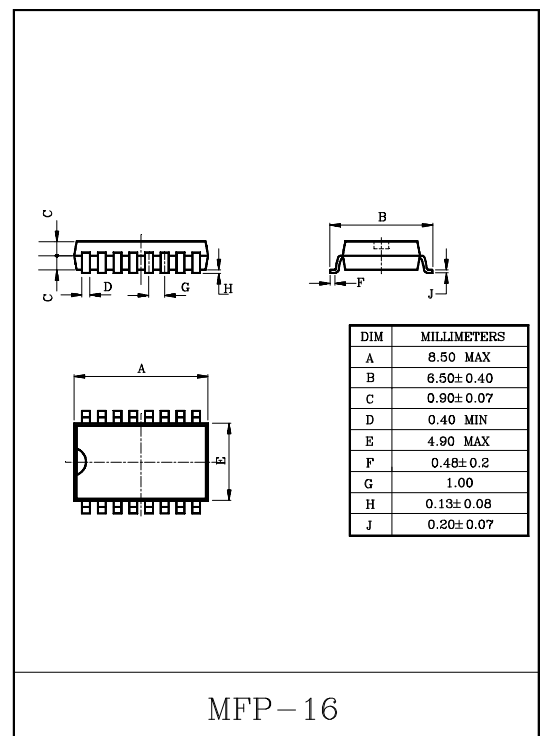
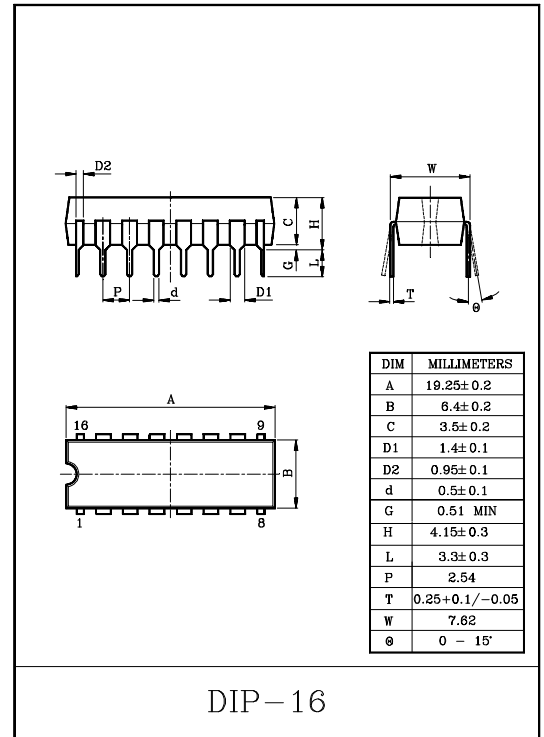

KIA2025P/F

ELECTRICAL CHARACTERISTICS

(Unless otherwise specified, $V_{CC}=9V$, $f=1kHz$, $R_L=10k\Omega$, $R_g=600\Omega$, $T_a=25^\circ C$, Normal EQ)

CHARACTERISTIC	SYMBOL	TEST CIRCUIT	TEST CONDITION	MIN.	TYP.	MAX.	UNIT
Quiescent Current	$I_{CCQ(1)}$	-	$V_{IN}=0$, Normal EQ	-	6.0	-	mA
	$I_{CCQ(2)}$	-	$V_{IN}=0$, Metal EQ	-	7.0	10.0	
Open Loop Voltage Gain	G_{VO}	-	$C_f=100\mu F$, $R_f=0$	-	100	-	dB
Maximum Output Voltage	V_{OM}	-	THD=0.5%	1.5	2.1	-	V_{rms}
Total Harmonic Distortion	THD	-	$V_{OUT}=0.5V_{rms}$	-	0.01	0.06	%
Equivalent Input Noise Voltage	V_{NI}	-	$R_g=620\Omega$, NAB BW=20Hz~20kHz	-	0.6	1.2	μV_{rms}
Input Resistance	R_{IN}	-	-	-	330	-	k Ω
Ripple Rejection	R.R	-	$f=100Hz$, $V_{IN}=1V_{rms}$	-	56	-	dB
Cross Talk	C.T	-	$V_{OUT}=0.775V_{rms}$ (0dBm)	50	60	-	dB
Forward/Reverse Cross Talk	C.T(F/R)	-	$V_{OUT}=0.775V_{rms}$ (0dBm)	60	70	-	dB

BLOCK DIAGRAM

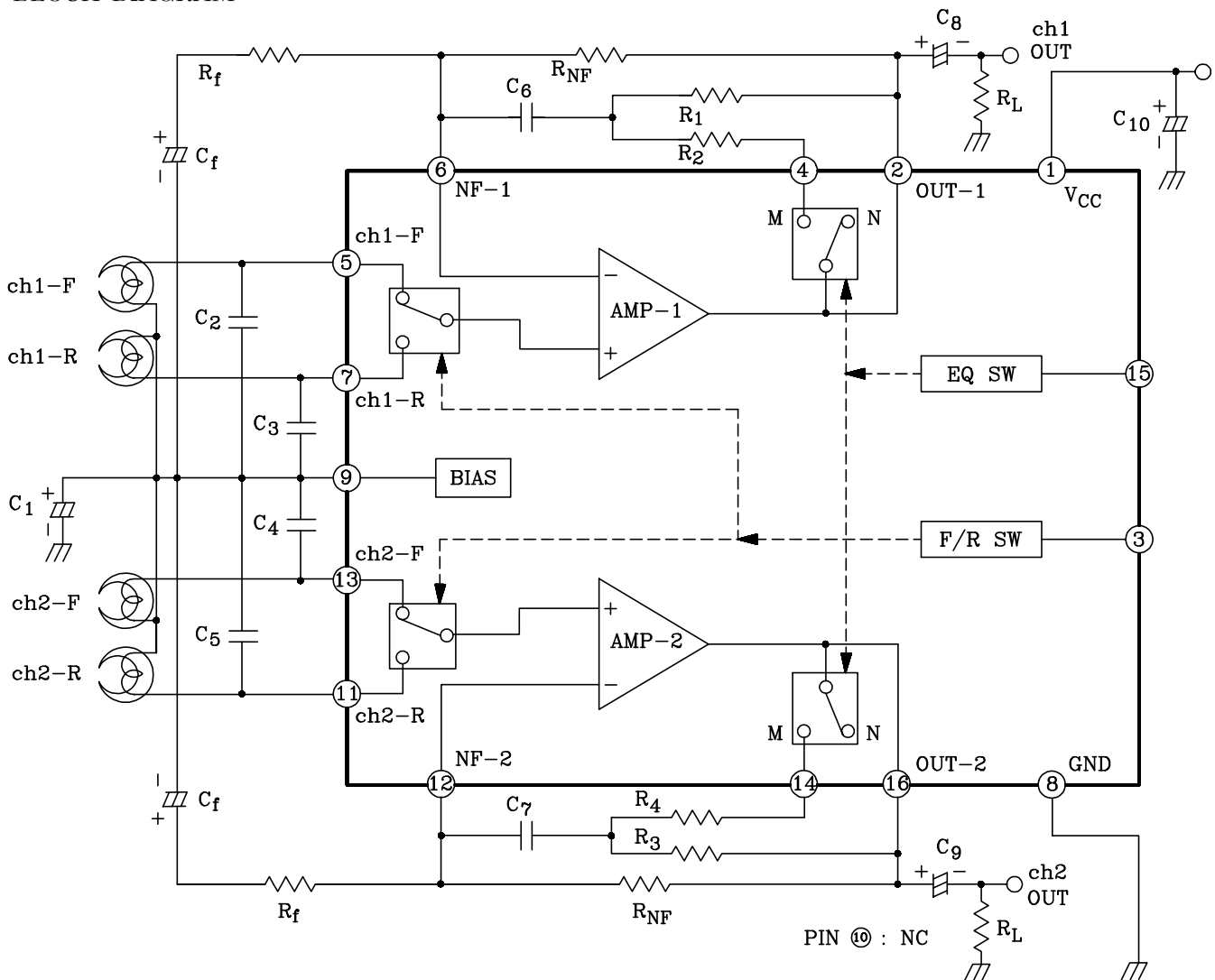

KIA2025P/F

APPLICATION CIRCUIT

